

Hartford Mall Retail/Office Space

110 W. Highway 38 Hartford, SD, 57033



The Hartford Mall is located in a high traffic retail area adjacent to the Sunshine grocery store. Lot has ample parking. Suites have large signage above doors as well as on the building facing a high traffic road. Mall neighbors include a sports bar, hair salon, laundromat, physical therapy, Napa Auto Store and more.

- Suite D is Available
 - 3,200 +/- Square Feet. \$2,133.33 /month
- Suite E is Available
 - 1,074 +/- Square Feet. \$917.38 /month
- Suite G is Available
 - 1,276 +/- Square Feet. \$1,089.92 /month

* Suite D & E can be leased together (\$8 PSF)

*All leases are Gross plus Utilities (Gas, Electric, Trash)

FOR LEASE

Price

\$10.25 / Square Foot

Addl. Pricing: \$8 PSF for Suite D. Gross + Utilities

Details

Type: Retail, Office

Available: Suite G: Immediately. Suite D & E: April 1, 2016

Stories: 1

Baths: other

Parking Capacity: 21-50

Construction: Frame

Roof: Composition

Heat: Unit Heater

Heat Source: Natural Gas

Air Conditioning: Central

Possession: Negotiable

Located in high traffic area

Adjacent to the grocery store

Ample Parking

Large Signage



Kirby Proehl
3408 S Sycamore Ave.
Sioux Falls, SD 57110
Cell: 605-366-8030
Fax: 605-371-1560
kirby@harr-lemme.com



Paul Gourley
3408 S Sycamore Ave.
Sioux Falls, SD 57110
Cell: 605-359-1968 Cell/Text
Fax: 605-371-1560
phgourley@gmail.com

Information deemed reliable but not guaranteed

Additional Photos



Information deemed reliable but not guaranteed

Floorplan

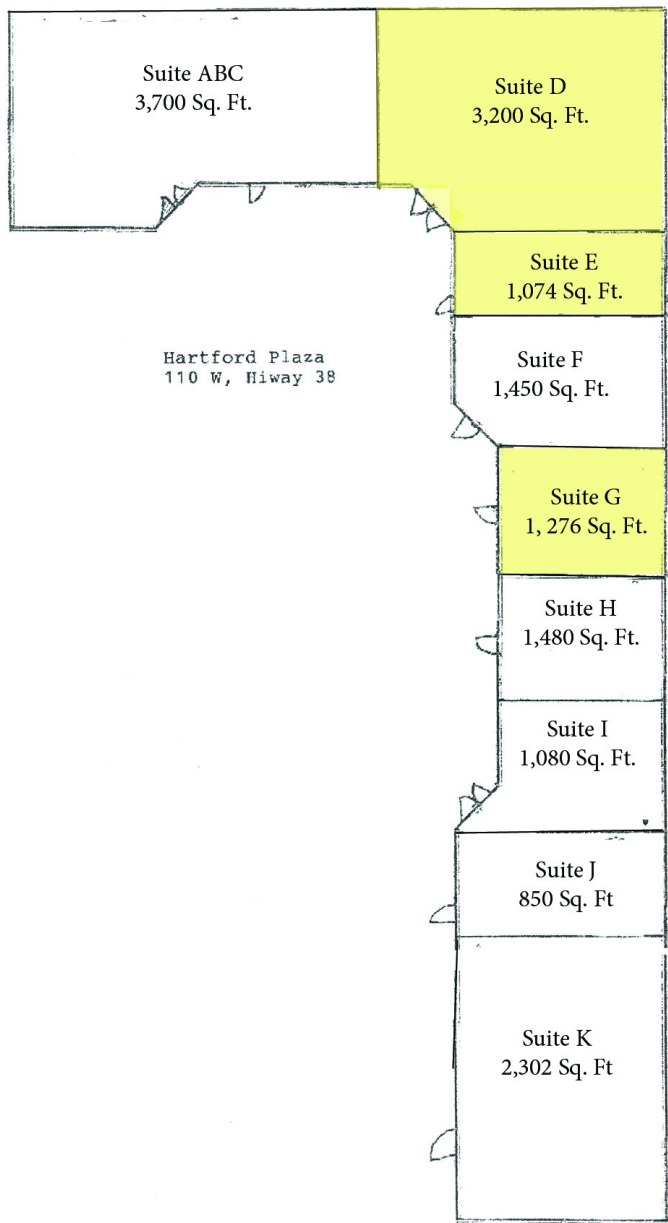

Available

Suite D & E
can be leased separate
or together

Information deemed reliable but not guaranteed

Location

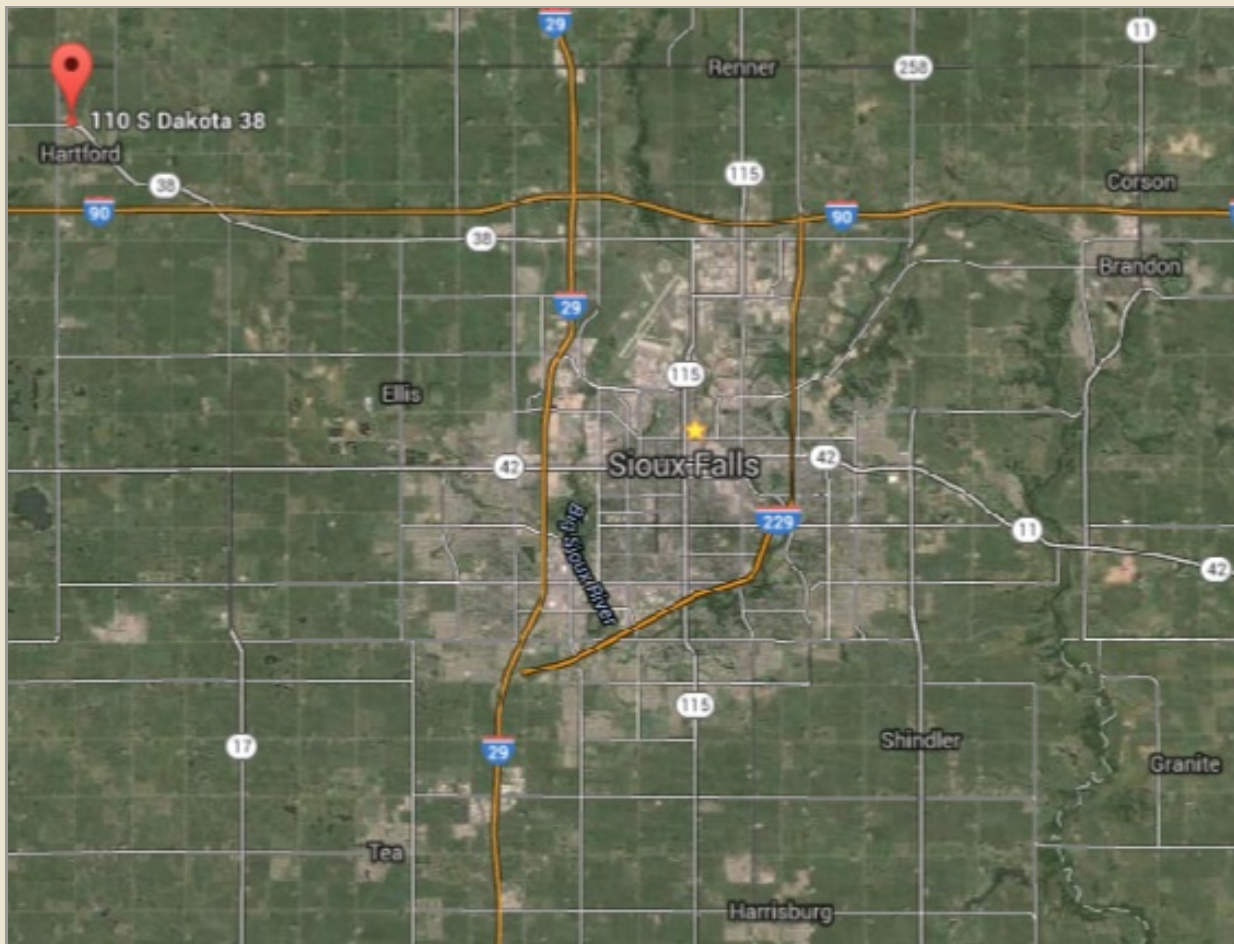
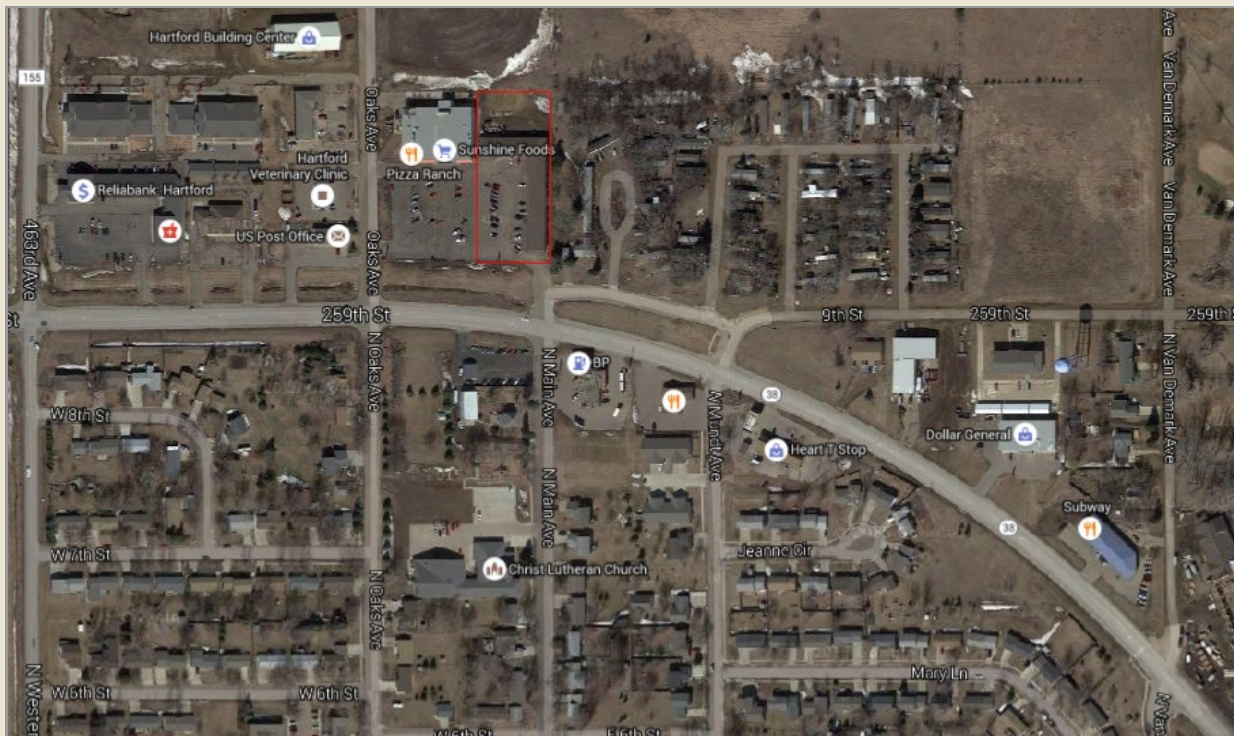

Information deemed reliable but not guaranteed